

Electric spindle for grinding

Spindle type	Speed (r/min)	Motor				Dimensions(mm)								Lub	Spindle nose dimension				Bearings type
		KW	V	A	Hz	D	D1	D2	S	L	L1	L2	d		M	L3	L4		
AD170-6/9	6000	9	350	20.3	200	170	140	58	50	409	59	24	Oil fog	38	M36x2	50	25	2x7212C/P4 2x7209C/P4	
ADW170-9/12	9000	12	350	25.3	300	170	133	58	50	408	43	24	Oil fog	38	M36x2	50	25	2x7012C/P4 2x7208C/P4	
ADW170-9Z/12	9000	12	350	25.3	300	170	133	53	46	408	44	24	Oil fog	33	M33x1.5	50	25	2x7011C/P4 2x7208C/P4	
ADW170-12Z/7	12000	7	220	23.8	200	170	124	43	36	364	56	23	Oil fog	25	M24x1.5	27	25	2x7209C/P4 2x7208C/P4	
ADL170-12/10	12000	10	350	23	400	170	124	53	50	364	43	27.5	Oil fog	33	M33x1.5	50	25	2x7011C/P4 2x7208C/P4	
ADL170-12Z/10	12000	10	350	23	400	170	124	48	41	359	40	23.5	Grease	28	M27x1.5	44	27	2x7010C/P4 2x7208C/P4	
ADL170-12/12	12000	12	350	28	400	170	124	53	50	389	43	27.5	Oil fog	33	M33x1.5	50	25	2x7011C/P4 2x7208C/P4	
ADQ170-12/15	12000	15	350	34	400	170	143	62	55	398	73	29	Oil fog	40	M36x2	60	25	2x7013C/P4 2x7209C/P4	
ADL170-15/10	15000	10	350	23	500	170	114	48	41	352	38	24	Oil fog	28	M27x1.5	42	25	2x7010C/P4 2x7009C/P4	
ADL170-18/10	18000	10	350	23	600	170	118	43	36	345	48	21	Oil fog	25	M24x2	45	25	2x7009C/P4 2x7008C/P4	
ADQ170-18/20	18000	20	350	43	600	170	126	48	41	430	45	23	Oil fog	28	M24x2	45	25	2x7010C/P4 2x7008C/P4	
ADQ170-24/16	24000	16	350	34	800	170	118	43	36	392	39	23	Oil fog	25	M24x2	45	25	2x7009C/P4 2x7007C/P4	
ADQ170-24/20	24000	20	350	46	800	170	118	43	36	420	39	23	Oil fog	25	M24x2	45	25	2x7009C/P4 2x7007C/P4	
AD190-6/10	6000	10	350	21	200	190	156	68	65	435	39	25	Oil fog	45	M42x2	49	38	2x7014C/P4 2x7211C/P4	
ADW190-7.5Z/20	7500	20	350	42	250	190	156	63	60	520	76	33	Oil fog	40	M36x2	54	38	3x7013C/P4 2x7211C/P4	
AD190/150-6Z/10	6000	10	350	21	200	190	150	57	50	381	253	25	Oil fog	36	M33x1.5	49	25	3x7212C/P4 2x7210C/P4	
ADW190-15/20	15000	20	350	43	500	190	144	53	50	389	45	26	Oil fog	32	M30x2	50	25	2x7011C/P4 2x7009C/P4	
ADQ200-6/20	6000	20	350	43	200	200	170	68	65	525	103	32	Oil fog	45	M42x2	54	38	4x7014C/P4 2x7211C/P4	
AD100-36Z/2S	36000	2	220	9	600	100	79	18	15	222	46	10	Oil fog	9	M8x1.25L	12	16	2xB7004C/P4 2xB7002C/P4	
AD110-30/4.5	30000	4.5	350	11.6	500	110	81	20	25	328	30	80						2xB7006C/P4 2xB7005C/P4	
ADQF165-36/4.3	36000	4.3	220	33.2	600	165	85	23	20	175	17	12						2xB7005C/P4 2xB7004C/P4	
ADW190-15Z/20S	15000	20	350	42.1	500	190	—	—	—	404	—	—						2xB7009C/P4	
																		2xB7008C/P4	
ADL200-1.5/5.5	1500	5.5	380	12.7	100	200	160	—	—	391	339	100	Oil fog	1:5				4x7213C/P4 2x7210C/P4	
ADL150-12Z/6.5	12000	6.5	350	14	400	150	43	34	—	—	—	—						2xB7009C/P4 2xB7008C/P4	

Electric spindle for grinding

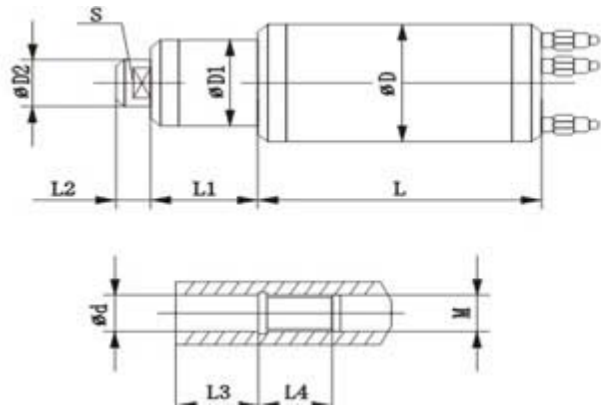

Spindle type	Speed (r/min)	KW	V	A	Hz	Dimensions(mm)						Lub	Spindle nose Dimension				Bearings type	
						D	D1	D2	S	L	L1		L2	d	M	L3		L4
AD70-60/1	60000	1	132	4.7	1000	70	48	12	9	137	9	11	Oil fog	6	M6x1	10	9	1x7001C/P4
AD80-60/1.5	60000	1.5	220	6	1000	80	55	15	13	137	9	11	Oil fog	8	M8x1.25	16	18	1x7002C/P4
AD80-60/2	60000	2	350	6	1000	80	55	16.8	14	183	7	9	Oil fog	9	M8x1.25	12	15	1x7001C/P4
AD80-90/1.5	90000	1.5	220	4.7	1500	80	50	12	9	137	9	11	Oil fog	6	M6x1	8	9	1x7003C/P4
ADQ80-90/2.5	90000	2.5	350	5.4	1500	80	50	12	10	272	6	8	Oil fog	7	M6x1	12	12	1x7002C/P4
ADW80-100/1.2	100000	1.2	220	4.7	1666	80	40	12	9	221	4	11.5	Oil fog	6.7	M12x0.75 (Outside)	3	6.5	2x7001C/P4
ADW100-60/2.5	60000	2.5	306	7.2	1000	100	64	16	14	220	31	9	Oil fog	9	M8x1.25	12	15	1x7000C/P4
AD120-36/2.7	36000	2.7	264	7.7	600	120	84	23	19	237	43	16	Oil fog	14	M14x1.5	21	19	2x7003C/P4
AD120-36Z/2.7	36000	2.7	264	7.7	600	120	84	18.5	16	232	54	16	Oil fog	10	M10x1.5	12	16	2x7005C/P4
ADL120-36/5.5	36000	5.5	350	12	600	120	91	28	24	271	36	14	Oil fog	16	M16x1.5	26	17	2x7002C/P4

Electric spindle for grinding

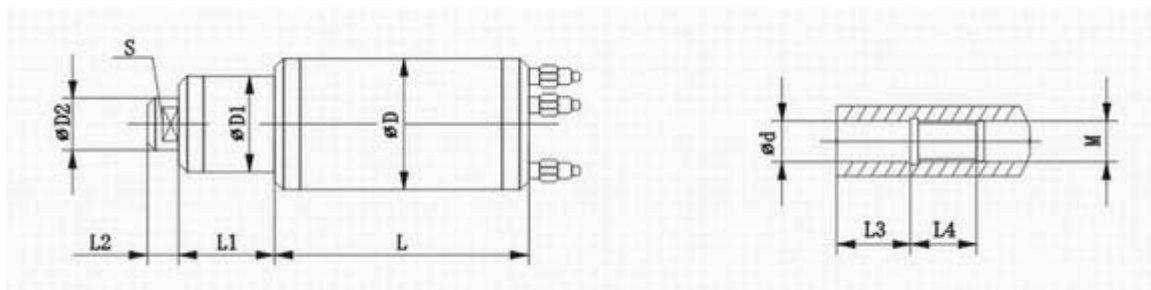

Spindle type	Speed (r/min)	Motor				Dimensions(mm)							Lub	Spindle nose dimensions				Bearingstype
		KW	V	A	Hz	D	D1	D2	S	L	L1	L2		d	M	L3	L4	
ADL120-42/6	42000	6	350	12.5	700	120	84	23	19	244	28	15	Oil fog	14	M14x1.5	18	19	2x7005C/P4
ADQ120-42/10	42000	10	350	15.4	700	120	84	23	19	256	43	15	Oil fog	14	M14x1.5	25	19	2x7004C/P4
ADQ120-45/7.5	45000	7.5	350	16	750	120	80	33	30	273	30	13	Oil fog	15	M14x1.5	8	22	2x7006C/P4
ADL120-48/5	48000	5	350	12.5	800	120	84	23	19	250	30	15	Oil fog	14	M14x1.5	19	22	2x7005C/P4
ADQ120-48/8	48000	8	350	14	800	120	84	23	19	256	43	16	Oil fog	14	M14x1.5	25	19	2x7004C/P4
ADQ120-51/8	51000	8	350	14	850	120	78	18	16	240	43	16	Oil fog	10	M10x1.5	16	14	2x7006C/P4

ADQ120-60/6	60000	6	350	11	1000	120	64	15.8	14	220	31	10	Oil fog	9	M8x1.25	15	14	2x7003C/P4
																		2x7002C/P4
ADQ120-75/5	75000	5	350	9.4	1250	120	70	13.5	12	203	26	12	Oil fog	8	M8x1	16	12	2x7002C/P4
																		2x7002C/P4
AD140-24Z/2.5	24000	2.5	220	7.9	400	140	88	28	24	210	58	16	Oil fog	14	M14x1.5	19	20	2x7006C/P4
																		2x7005C/P4
AD140-24Z/4	24000	4	220	15.2	800	140	95	28	24	244	43	16	Grease	16	M14x1.5	28	23	2x7006C/P4
																		2x7005C/P4
AD140-30Z/3.6	30000	3.6	220	14	500	140	84	23	19	234	53	15	Grease	14	M14x1.5	21	19	2x7005C/P4
																		2x7004C/P4
ADL140-36/5.5	36000	5.5	350	12	600	140	95	28	24	264	36	16	Oil fog	16	M16x1.5	24	19	2x7006C/P4
																		2x7005C/P4
AD150-12Z/4.5	12000	4.5	293	11.9	400	150	114	38	32	235	57	21	Grease	20	M16x1.5	27	24	2x7208C/P4
																		2x7208C/P4
AD150-15/10	15000	10	350	22	500	150	120	48	41	365	48	21	Oil fog	28	M27x1.5	42	25	2x7010C/P4
																		2x7008C/P4
ADW150-18Z8/5.5	18000	5.5	220	19.6	300	150	104	38	32	319	50	21	Grease	20	M18x1.5	27	25	2x7008C/P4
																		2x7006C/P4
ADL150-18/10	18000	10	350	23	600	150	118	43	36	345	48	21	Oil fog	25	M24x2	45	25	2x7009C/P4
																		2x7008C/P4

Contact Us:

Anyang General International Co.,Ltd

Add: Suite A, 4/F Jinhao Business Bld., Renmin Rd., Anyang, Henan, P.R.C.

Zip Code: 455000

Tel: (86) 372 5965148

Fax: (86) 372 5951936

[Http://www.gcmachines.com](http://www.gcmachines.com)

E-mail: info@agico.com.cn