

The High Frequency Spindles for Grinding

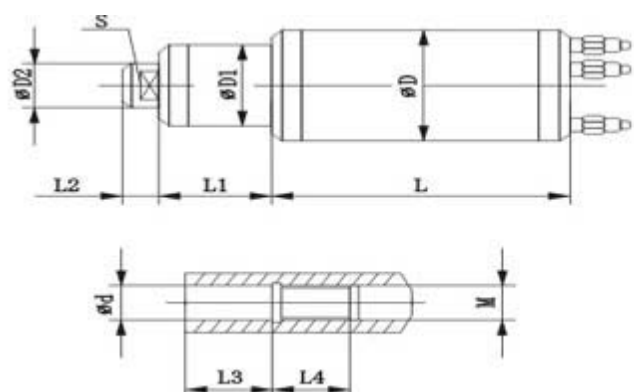

Spindle type	Speed (r/min)	Motor				Dimensions(mm)							Lub	Spindle nose dimension				Bearingstype
		KW	V	A	Hz	D	D1	D2	S	L	L1	L2		d	M	L3	L4	
ADW150-24Z/4.5	24000	4.5	293	10.4	400	150	94	28	24	237	50	17	Grease	16	M14x1.5	25	22	2x7006C/P4 2x7005C/P4
ADL150-24/7.3	24000	7.3	293	19.6	400	150	118	38	32	325	42	19	Oil fog	22	M22x2	40	19	2x7008C/P4 2x7007C/P4
ADL150-24/7.3Q	24000	7.3	293	19.6	400	150	118	38	32	340	38	19	Oil gas	22	M22x2	40	19	2x7008C/P4 2x7007C/P4
ADQ150-24/12	24000	12	350	25.5	800	150	118	38	32	328	39	20	Oil fog	22	M22x2	40	19	2x7008C/P4 2x7007C/P4
ADQ150-30/10	30000	10	350	22	500	150	115	33	30	296	33	14	Oil fog	20	M22x1.5	26	17	2x7007C/P4 2x7006C/P4
ADQ150-36/8.5	36000	8.5	350	19	600	150	105	28	24	280	32	14	Oil fog	16	M16x1.5	26	17	2x7006C/P4 2x7005C/P4
ADW160-24Z/6	24000	6	293	15.5	400	160	104	33	30	297	47	22	Grease	20	M20x1.5	26	19	2x7007C/P4 2x7005C/P4
ADW160-18Z/5.5	18000	5.5	220	19.6	300	160	104	38	32	319	43	28	Grease	20	M18x1.5	26	28	2x7008C/P4 2x70068C/P4
ADL160-18/10	18000	10	350	23	600	160	118	43	36	345	48	21	Oil fog	25	M18x1.5	45	25	2x7009C/P4 2x7008C/P4
AD170-6/6	6000	6	350	15	200	170	140	58	50	359	24	24	Oil fog	38	M36x2	50	25	2x7212C/P4 2x7209C/P4

Contact Us:

Anyang General International Co.,Ltd

Add: Suite A, 4/F Jinhao Business Bld., Renmin Rd., Anyang, Henan, P.R.C.

Zip Code: 455000

Tel: (86) 372 5965148

Fax: (86) 372 5951936

[Http://www.gcmachines.com](http://www.gcmachines.com)

E-mail: info@agico.com.cn